

LB Series 621mm Emergency Bar

- Heavy Duty Emergency Bar
- High Brightness 48 Watt Output
- 10 Selectable Flash Patterns
- IP67 Ingress Protection
- Voltage Range 10-30 Volt
- 2 Year Warranty

Function Amber Emergency Bar
Size 621mm x 206mm x 85mm
Voltage Multivolt 10-30V
LED Qty 96 x 0.5 Watt
LED Lifespan 30,000 Hours
Beam Angle 360° Omnidirectional
Cable 50cm
Temp Range -40°C to +60°C

Draw
@12V 3A
@24V 1.6A
Lens Polycarbonate
Base Polycarbonate
Fittings Painted Steel

| No | Flash Pattern |
|----|---------------------------------------|
| 1 | Rotate |
| 2 | Single (Class 1, LB621/862/1103/1345) |
| 3 | Quad (LB252ACM Class1 Only) |
| 4 | Quint Split |
| 5 | Single/Triple/Quint |

| No | Flash Pattern |
|----|-------------------------|
| 6 | Fast/Slow Split |
| 7 | Sequential Combine |
| 8 | Left/Right Split/Single |
| 9 | Random 1 |
| 10 | Random 2 |

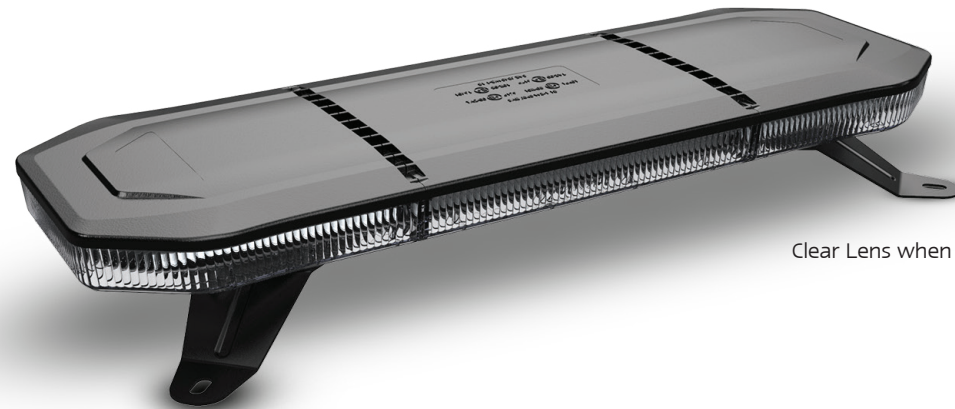

Clear Lens when Inactive

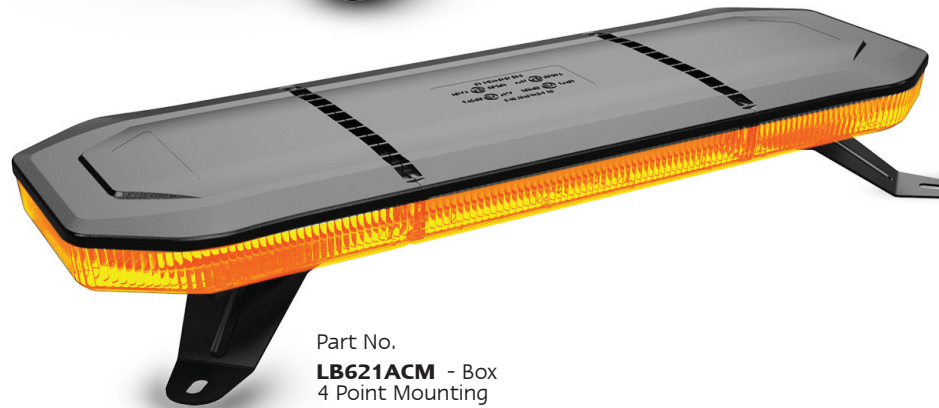

Part No.
LB621ACM - Box
 4 Point Mounting

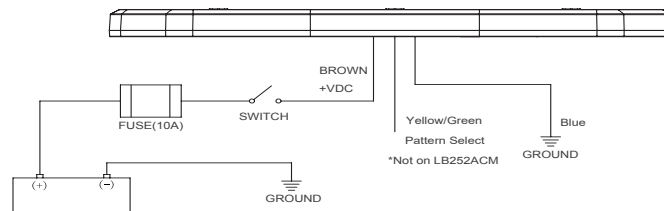

Next Pattern, Touch Brown +VDC to the Green wire for 0.5 sec.
 Return to Default Pattern #1, Touch Brown +VDC to the Green wire for 2.5 sec.

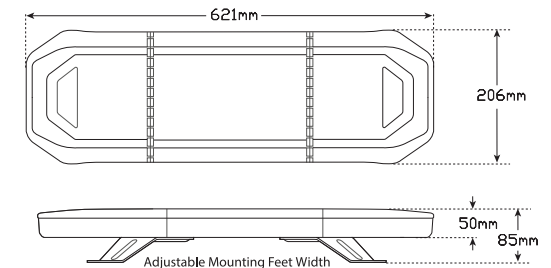

J845
 Class 1
ECE R10
 Approved
IP67
 Protection
2 Year
 Warranty



All enquiries P: (03) 9466 7075 E: led@ledtech.com.au, www.ledautolamps.com

All efforts are made to ensure all information is correct and up to date, it can be subject to change without notice. All measurements are in millimeters (mm) and are not to scale.

© All LED Technologies designs are registered throughout the world. - Current as of 24/03/2020



LED EMERGENCY BAR

R10 APPROVED - SAE/J845 Class 1 Compliant

Operating Instructions

Part No. LB252ACM LB621ACM LB862ACM LB1103ACM LB1345ACM

IMPORTANT! Read all instructions before installing and operating emergency bar. This manual must be delivered to the end user. This manual assumes installation by a suitably qualified automotive technician.

SPECIFICATIONS:

| | |
|----------------|---|
| Function | Emergency Bar |
| LED Colour | Amber |
| Voltage Range | 10–30VDC |
| Max Power | 30W/48W/64W/80W/96W |
| LED# | 30/96/128/160/192 |
| Flash Pattern# | Quad Flash Pattern (LB252ACM) 10 Flash Patterns (LB621/862/1103/1345ACM) |
| Approval | ECE R10, SAE/J845 Class 1 |
| IP Rating | IP67 |
| Lens | Polycarbonate |
| Mounting | Single Bolt/Bracket (LB252ACM only) 4 Point Fixed Base |

| No | Flash Pattern |
|----|---------------------------------------|
| 1 | Rotate |
| 2 | Single (Class 1, LB621/862/1103/1345) |
| 3 | Quad (LB252ACM Class1 Only) |
| 4 | Quint Split |
| 5 | Single/Triple/Quint |

| No | Flash Pattern |
|----|-------------------------|
| 6 | Fast/Slow Split |
| 7 | Sequential Combine |
| 8 | Left/Right Split/Single |
| 9 | Random 1 |
| 10 | Random 2 |

4 Point Fixed Base

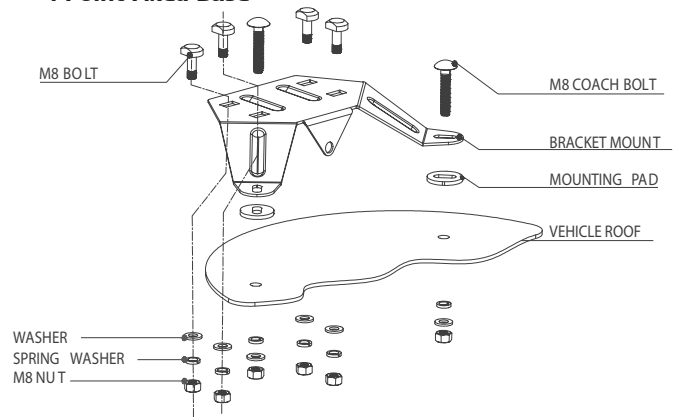

Single Bolt/Bracket (LB252ACM only)

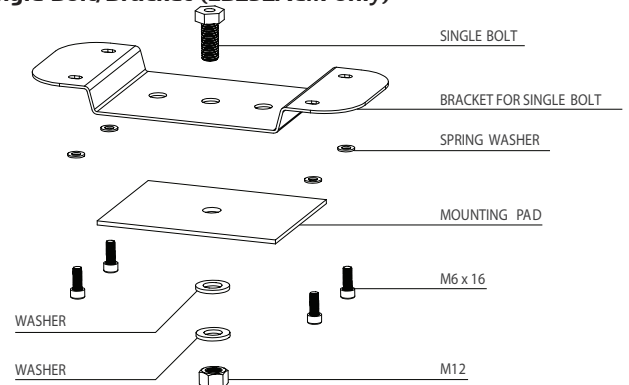

PRE-INSTALLATION:

- Carefully unpack and inspect the emergency bar and all mounting accessories before attempting installation. If any parts are found to be damaged or missing please contact your LED Autolamps distributor for advice.
- Plan all cable routing before proceeding with installation. When drilling vehicle surface ensure the area is free from any wires, fuel lines, upholstery, air bags etc. that could be damaged.

MOUNTING LOCATION:

Ensure the chosen mounting location is a smooth flat area of the vehicle roof. Position the emergency bar centrally to the vehicle's width. When mounting the product ensure it is level from front-to-back and left-to-right. Ensure there are no obstructions limiting visibility to traffic

IMPORTANT! This unit is a safety device and it must be connected to its own separate, fused power point to assure its continued operation should any other electrical accessory fail. Do not wire in parallel with any other accessory. Disconnect the battery before wiring up the minibar, to prevent accidental shorting, arcing and/or electrical shock.

WIRING INSTRUCTIONS: Route wires from the vehicle positive feed to the switch panel in the cab. Use suitable high-temperature vehicle wire if it passes through the engine compartment. Install a suitable in-line fuse as close to the power feed as possible. Ensure emergency bar Black wire is connected to ground source on vehicle. Use cable ties and grommets to secure and protect all cables and wires.

⚠ If in doubt, please consult a qualified automotive electrician.

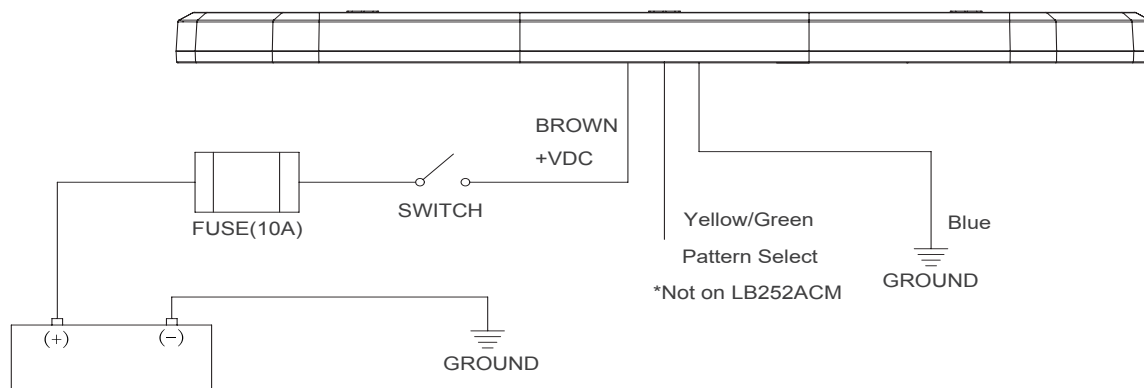

Next Pattern, Touch Yellow/Green wire to Brown +VDC for 0.5 sec.

Return to Default Pattern #1, Touch Yellow/Green wire to Brown +VDC wire for 2.5 sec.

Conditions with Warranty Against Defects

2 YEAR WARRANTY

This warranty covers faults in components and workmanship of the lamp itself when used under normal conditions and does not cover the following:

- Faulty installation
 - Over-voltage
 - Accidental damage
 - Freight charges
 - Excessive heat damage
 - Misuse or abuse
 - Cost of labour for removal and or replacement
 - Chemicals that damage plastics as per Chemical Resistance List
- (see our website for more information).

Making a Claim: All warranty returns must be tested off the vehicle to ensure that the unit is at fault. This can be done by directly attaching the lamps to a fully charged 12-volt battery. Do not replace any products unless you are 100% sure that the suspected faulty product will be covered under warranty. If the unit is faulty, call your place of purchase so it can be directed to the LED Technologies warranty department or contact the LED Autolamps warranty department direct for full testing, evaluation, and warranty repairs.

If you consider the lamp to be faulty, disconnect the wiring of the lamp, remove nuts from bolts and send to: **LED Autolamps Reply Paid 90350, PO Box 2107 Bundoora VIC 3083**, allow five business days for evaluation. Please ensure returned warranties/credits have a completed Warranty Claim Form, which is found on our website under the "Warranty" Tab.

Our goods come with guarantees that cannot be excluded under the Australian Consumer Law. You are entitled to a replacement or refund for a major failure and compensation for any other reasonably foreseeable loss or damage. You are also entitled to have the goods repaired or replaced if the goods fail to be of acceptable quality and the failure does not amount to a major failure.

For more information, contact

LED Autolamps

Phone 03 9466 7075, Email led@ledtech.com.au

or visit our website www.ledautolamps.com.

Head Office 42 Enterprise Drive Bundoora Vic 3083